

# WHELEN<sup>®</sup>

ENGINEERING COMPANY INC.

Route 145, Winthrop Road,

Chester, Connecticut 06412

Phone: (860) 526-9504

Fax: (860) 526-4078

Internet: [www.whelen.com](http://www.whelen.com)

Sales e-mail: [autosale@whelen.com](mailto:autosale@whelen.com)

Canadian Sales e-mail: [autocan@whelen.com](mailto:autocan@whelen.com)

Customer Service e-mail: [custserv@whelen.com](mailto:custserv@whelen.com)

Installation Guide:  
Guardian™ Lightbar  
(with Beacons & Power Supply)  
Models: G7M\* / G7P\* / G7M\*\*\* / G7P\*\*\*

## Safety First

This document provides all the necessary information to allow your Whelen product to be properly and safely installed. Before beginning the installation and/or operation of your new product, the installation technician and operator must read this manual completely. Important information is contained herein that could prevent serious injury or damage.

- Proper installation of this product requires the installer to have a good understanding of automotive electronics, systems and procedures.
- If mounting this product requires drilling holes, the installer **MUST** be sure that no vehicle components or other vital parts could be damaged by the drilling process. Check both sides of the mounting surface before drilling begins. Also de-burr any holes and remove any metal shards or remnants. Install grommets into all wire passage holes.
- If this manual states that this product may be mounted with suction cups, magnets, tape or Velcro™, clean the mounting surface with a 50/50 mix of isopropyl alcohol and water and dry thoroughly.
- Do not install this product or route any wires in the deployment area of your air bag. Equipment mounted or located in the air bag deployment area will damage or reduce the effectiveness of the air bag, or become a projectile that could cause serious personal injury or death. Refer to your vehicle owners manual for the air bag deployment area. The User/Installer assumes full responsibility to determine proper mounting location, based on providing ultimate safety to all passengers inside the vehicle.
- For this product to operate at optimum efficiency, a good electrical connection to chassis ground must be made. The recommended procedure requires the product ground wire to be connected directly to the **NEGATIVE (-)** battery post.
- If this product uses a remote device to activate or control this product, make sure that this control is located in an area that allows both the vehicle and the control to be operated safely in any driving condition.
- Do not attempt to activate or control this device in a hazardous driving situation.
- This product contains either strobe light(s), halogen light(s), high-intensity LEDs or a combination of these lights. Do not stare directly into these lights. Momentary blindness and/or eye damage could result.
- Use only soap and water to clean the outer lens. Use of other chemicals could result in premature lens cracking (crazing) and discoloration. Lenses in this condition have significantly reduced effectiveness and should be replaced immediately. Inspect and operate this product regularly to confirm its proper operation and mounting condition. Do not use a pressure washer to clean this product.
- It is recommended that these instructions be stored in a safe place and referred to when performing maintenance and/or reinstallation of this product.
- **FAILURE TO FOLLOW THESE SAFETY PRECAUTIONS AND INSTRUCTIONS COULD RESULT IN DAMAGE TO THE PRODUCT OR VEHICLE AND/OR SERIOUS INJURY TO YOU AND YOUR PASSENGERS!**

**For warranty information regarding this product, visit [www.whelen.com/warranty](http://www.whelen.com/warranty)**

## Installation:

- Since this installation will require drilling, It is absolutely necessary to make sure that no other vehicle components will be damaged in the process. Check both sides of the mounting surface before starting and if damage is possible, select a different mounting location.
- Always deburr all holes and remove any metal filings from the vehicle.

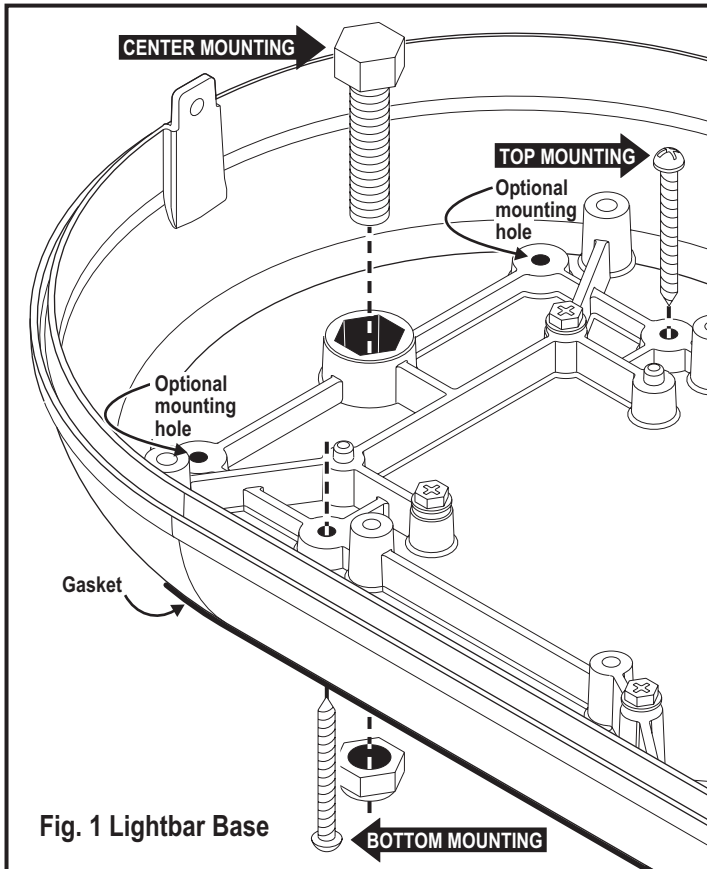

## Top Mount:

1. Remove the 2 screws at each end of the lightbar that secure the dome to the base and remove the dome.
2. With a 3/16" drill bit, drill out the 4 mounting bosses in the base for clearance holes for #8 sheet metal screws (Figs. 1 & 2).
3. Be sure the mounting area is relatively flat. Using the lightbar base as a template, scribe the 4 mounting hole locations onto the mounting surface.
4. Mark off the wire access hole located right behind the lightbar.

5. Drill the mounting holes you marked off in step 3 with a #29 drill bit and the wire access hole with a 3/8" drill bit.
6. Install a 3/8" rubber grommet in the wire access hole and route the wires through, then apply a silicone sealing compound around the wires and grommet.
7. Carefully position the lightbar over the mounting holes and secure the lightbar to the mounting surface using the #8 sheet metal screws supplied.
8. Replace the dome with the 2 screws removed in step 1.

## Bottom Mount:

1. Be sure the mounting area is relatively flat. Using the information in figure 2 scribe the 4 mounting hole locations onto the mounting surface.
  2. Mark off the wire access hole, located right behind the lightbar.
  3. Drill the mounting holes you marked off in step 1 with a 3/16" drill bit and the wire access hole with a 3/8" drill bit.
  4. Install a 3/8" rubber grommet in the wire access hole and route the wires through, then apply a silicone sealing compound around the wires and grommet.
  5. Carefully position the lightbar over the mounting holes and secure the lightbar to the mounting surface using the #8 sheet metal screws supplied.
1. Be sure the mounting area is relatively flat. Using the information in figure 2 scribe the 2 mounting hole locations onto the mounting surface.
  2. Mark off the wire access hole, located right behind the lightbar.
  3. Drill the 2 mounting holes using an 11/32 drill bit and the wire access hole using a 3/8" drill bit.
  4. Tighten each locknut onto its bolt to draw the bolt head into the base than remove the locknuts.
  5. Align the bolts with the 2 mounting holes you drilled and position the lighththead onto the mounting surface.
  6. Install a 3/8" rubber access hole and route the wires through, then apply a silicone sealing compound around the wires and grommet.
  7. Secure the lightbar with the locknuts provided.

## Magnetic Mount:

**WARNING!** The use of any magnetic or suction cup mounted warning light on the outside of a vehicle, while in motion, is not recommended and is at the sole discretion and risk of the user.

Place the lightbar onto the vehicle, wire it to power and installation is complete. If you have the cigarette plug model, just plug it into your vehicle cigarette lighter and you are ready to go.

**Fig. 2 Mounting Holes**  
Top view of base

WIRE EXIT ● HOLE HERE

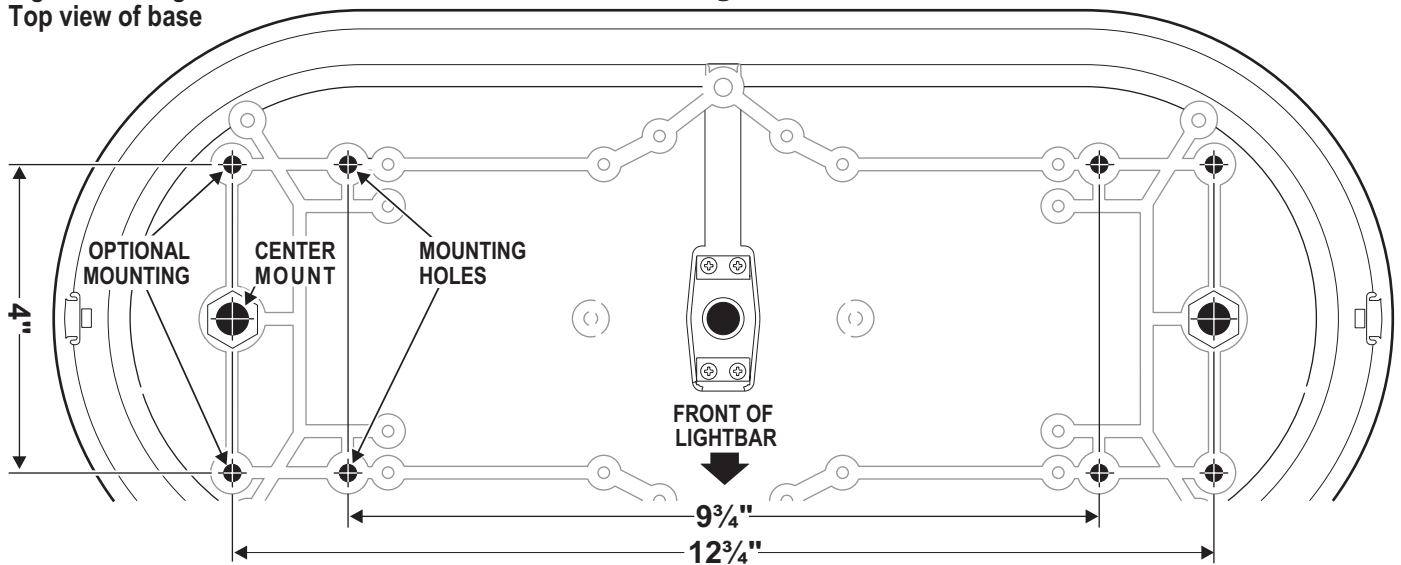

**Fig. 3 Flash Tube Replacement**

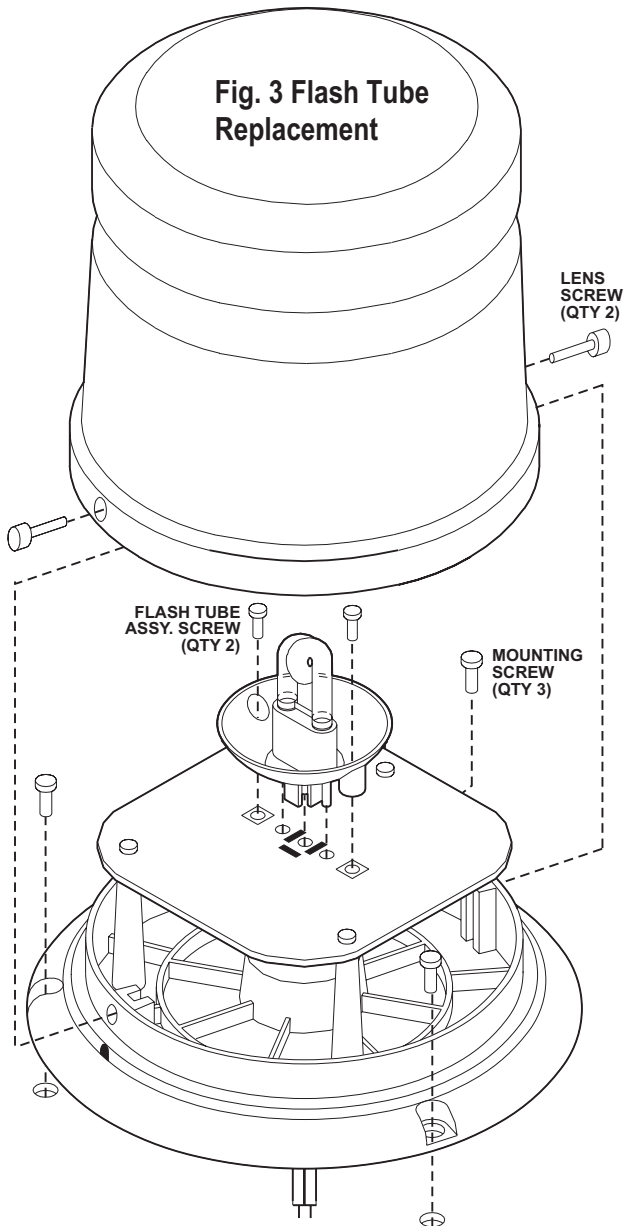

**Flash Tube Replacement:**

1. Remove the 2 screws at each end of the lightbar that secure the dome to the base and remove the dome.

**WARNING!** The strobe power supply is a high voltage device. Do not remove flash tubes or dismantle strobe light head assembly while in operation. Wait 10 minutes after turning power off before starting work or trouble shooting.

**Note:** If the edge of the base interferes with the screwdrivers access to the lens screw, you may have to remove the 3 mounting screws holding the beacon to the base and lift the beacon.

2. Remove the beacons lens screws and remove the lens. If your beacon is equipped with diamond mirrors, to gain access to the beacon lens screws you may have to first remove the mirrors
3. Install the new flash tube making sure to align the 3 prongs on the flash tube with the 3 slots in the power supply (Fig. 3).
4. Secure the new flash tube with its screws and reassemble the beacon and lightbar.

## The Guardian™ Power Supply:

If your lightbar comes equipped with the Guardian™ strobe power supply, you will have a choice of 10 changeable flash patterns. This power supply also comes with a Hi-Low feature to switch the beacons from high to low power. **These features are only available on permanent mount models.**

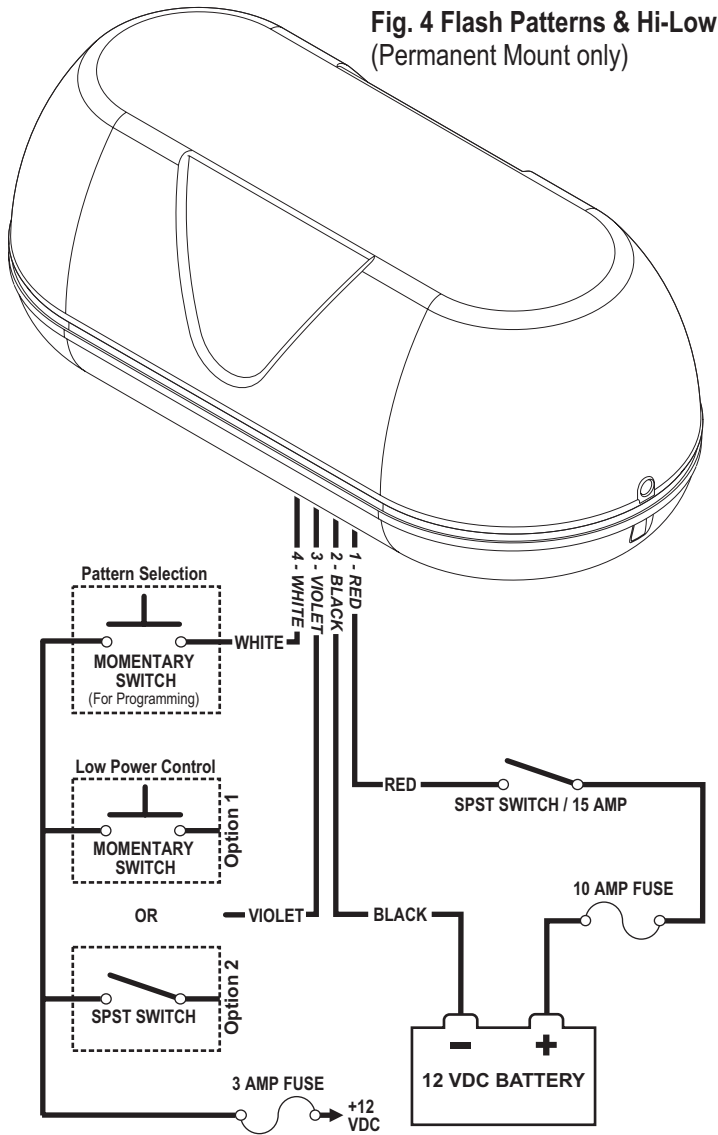

### Specifications: Guardian™ Power Supply

Input Voltage	12.8 / 25.6 VDC ±20
Input Current	3 AMP/ 1.6 AMP
Flash Rate	120 CFPM
Fill Flash	100ms
Energy	HI 1.9/1.9/1.9/6 JOULES LO 1.9/1.9/1.9/1.9 JOULES
Default Pattern	CometFlash®

## Wiring:

**WARNING! The strobe light power supply is a high voltage device. Do not touch or remove tube assembly in strobe light head assemblies while in operation. Wait 10 minutes after disconnecting the unit from its power source before starting work or troubleshooting on power supply or system.**

**WARNING! All customer supplied wires that connect to the positive terminal of the battery must be sized to supply at least 125% of the maximum operating current and FUSED at the battery to carry that load. DO NOT USE CIRCUIT BREAKERS WITH THIS PRODUCT!**

**Note: All fuses and fuse blocks are customer supplied**

1. Extend the 4 wires exiting the lightbar to the designations shown in figure 4.
2. Connect the RED wire to a fuse block (customer supplied) and then to the POSITIVE terminal on the battery. Do not install the fuse until ALL of the wire connections are completed. Refer to the wiring diagram for the appropriate fuse value needed.
3. Connect the black wire to the factory chassis ground typically adjacent to the battery.

### Low Power Control / Violet:

The type of switch used depends on how the operator wishes the Hi/Low feature to function:

**Latching Mode:** By applying +voltage to the VIOLET power supply wire for less than 1 sec., the power supply is “latched” into low power operation. The unit must be turned off and then back on to restore normal, Hi power operation. A momentary switch is desired for this.

**Level Mode:** Applying +voltage to the VIOLET power supply wire for more than 1 sec. holds the power supply in low power mode until that voltage is removed. A toggle switch is desired for this.

### Pattern Selection / White:

This is a positive activation input. A momentary activation (less than 1 second) of the WHITE wire will change the default flash pattern to the next available pattern. If the new pattern is active for more than 1 second, it will become the new default pattern. A momentary activation (more than 1 second) will cause the power supply to change the default flash pattern to the previous available pattern. If the input is tied to positive while the unit is powered up, the default pattern will change to CometFlash®.

### Available Flash Patterns:

1 - CometFlash® 120	120 CFPM @ 200 mS/100mS
2 - TripleFlash™ 150	150 FPM @ 200 mS/100mS
3 - DoubleFlash 180	180 FPM @ 230 mS/100mS
4 - Single Flash 400	400 FPM @ 150 mS
5 - ActionFlash™	3 Comet 4 Singles
6 - ModuFlash™	175 FPM @ 384mS to 150mS
7 - MicroBurst II™	200 FPM @ 200mS/100mS
8 - MicroBurst III™	190 FPM @ 200mS/100mS
9 - LongBurst™	140 FPM @ 100 mS
10 - ActionScan™	All Patterns / Random