

Guardian™ Series

STROBE OR HALOGEN MINI LIGHTBARS



Sleek styling, superior light output, universal mounting, as well as quiet and reliable operation make the Guardian Series of products your first choice for warning protection.



G7MCRB
Magnetic
Mount



G1VA / G2VA
Magnetic/Suction
Mount



G7PA
Permanent
Mount

The Guardian Series is available in permanent, magnetic or magnetic/suction mount variations to meet your every need.

Multi-color configurations available with clear and color domes and filter kits.

- Permanent bolt mount versions include 6" pigtail.
- Magnetic mount versions include four 50 lb. pull magnets.
- Magnetic/suction mount versions includes two 110 lb pull magnets overcoated with non-marring rubber with suction control.
- Magnetic and magnetic mount have 8' straight cord and new cigar plug with On/Off switch, includes fuse. Plug has a connector so if failure occurs, plug can easily be replaced.

HALOGEN G1 and G2 Series

- Attention getting G1 Series with 135 RPM rotators, or G2 Series with 175 RPM rotators.
- Brilliant full size diamond mirror provides a total of 540 FPM for G1 or 700 FPM for G2.
- High intensity 55 watt H1 bulbs (12 volt version).
- Large, precision engineered, wide-angle reflectors provide maximum intensity at all times.
- Quiet and reliable double ball bearing motor assembly with 3 year full factory warranty.
- Standard 12 VDC (24 VDC available upon request).

STROBE G7 Series

- G7 Series with two remote strobe heads and built-in remote power supply offers our attention getting, alternating CometFlash® and a 1/2 sized diamond mirror. The built-in strobe power supply provides 40 watts, 12 joules and 120 FPM (480 FPM total).
- Hi/Low intensity control, standard.
- 12-24 VDC.
- Multi-color configuration with clear outer dome and color inner domes.
- 2 year warranty on power supply and 6 month warranty on strobe flash tube.



WHELEN®

GUARDIAN™ SERIES

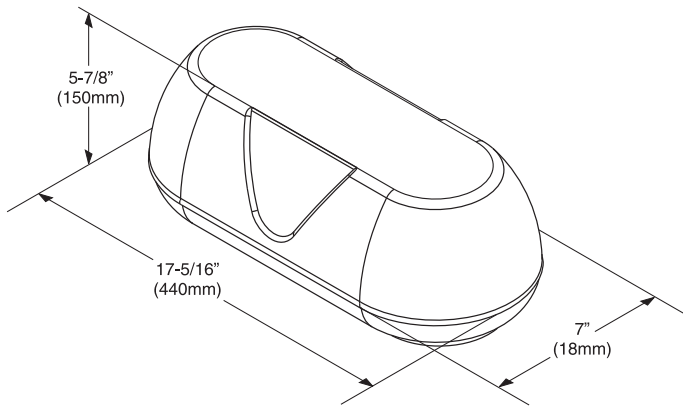

Guardian Series has choice of mounting holes.

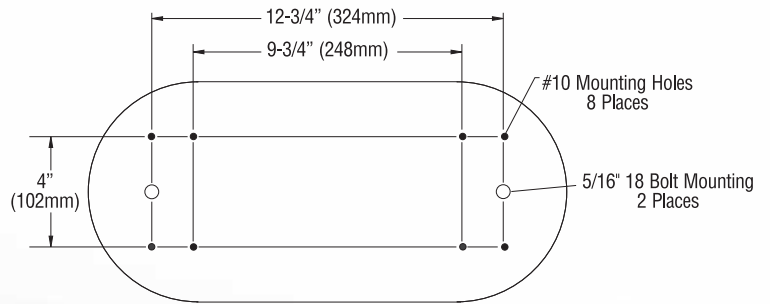

HALOGEN MODELS

G1 Series

Includes two 135 RPM rotators and full size diamond mirror.

G1M* magnetic mount.

G1P* permanent mount.

G1V* magnetic/suction mount.

G2 Series

Includes two high speed 175 RPM rotators and full size diamond mirror.

G2M* magnetic mount.

G2P* permanent mount.

G2V* magnetic/suction mount.

STROBE MODELS

G7 Series

Includes two remote strobe beacons, one built-in 40 watt power supply and half size diamond mirror.

G7M* magnetic mount, color outer dome.

G7P* permanent mount, color outer dome.

G7V* magnetic/suction mount, color outer dome.

G7MC** magnetic mount, clear outer dome, color inner domes.

G7PC** permanent mount, clear outer dome, color inner domes.

G7VC* magnetic/suction mount, clear outer dome, color inner domes.

OPTIONS

G1MM90.....90 lb. pull magnetic mount kit with cigar plug for G1 and G2 Series.

G7MM90.....90 lb. pull magnetic mount kit with cigar plug for G7 Series.

INSTLRDX.....Installation of G1MM90 or G7MM90 magnetic mount kit, permanent mount models only.

KCF*.....Inner filter kit for G1/G2 Series halogen models, customer installed (use with clear outer dome).



The use of any magnetic or magnetic/suction mounted warning beacon on the outside of a moving vehicle is not recommended and is at the sole risk of the user.

WHELEN®
ENGINEERING COMPANY, INC.

51 Winthrop Road
Chester, Connecticut 06412-0684
(860) 526-9504 • Fax: (860) 526-4078
www.whelen.com

Whelen Engineering reserves the right to upgrade and improve products without notice.
© 2010 Whelen Engineering Company, Inc. Printed in U.S.A.
NASCAR® is a registered trademark of the National Association for Stock Car Auto Racing, Inc.
Code No. 11457G - 06/10

American Employees, American Manufacturing, American Pride!