

NEW PRODUCT

ION™ Series

SURFACE MOUNTED SUPER-LED® LIGHT FOR INTERIOR AND EXTERIOR VEHICLE APPLICATIONS

**DASH
DECK
VISORS**



ION is a super-tough, ultra compact LED light that is perfect for mounting anywhere on your vehicle, inside or out.

ION shrugs off moisture, salt, chemicals and road vibration while providing added light for off-road vehicles, industrial equipment, motorcycles, utility vehicles, marine and many other heavy-duty applications. Compact and versatile enough to mount in any small space on emergency and rescue equipment.

FEATURES

- Smallest and most effective Super-LED light on the market.
- ION is a super-tough, water resistant, compact LED light that is perfect for inside/outside mounting anywhere on your vehicle.
- Single color models have 25 Scan-Lock™ flash patterns, while split colors offer 69 flash patterns to choose from.
- Synchronizable to other Whelen Synch products.
- Choice of black or white housings.
- Includes universal mount: combination permanent/pedestal, clip, edge mounts, double sided tape and new bail bracket mount.
- 0.40 amps average at 12.8 VDC.
- Supplied with 6" 4-wire pigtail.
- Meets or exceeds SAEJ595 specifications.
- Five year HDP® Heavy-Duty Professional warranty.

Replace * in model number with color desired:
A = Amber, B = Blue, R = Red, C = White



Mount in vehicle grille.



Mounted on trunk lid.

MODELS

- ION*Red, blue, amber or white, black housing
- IONJSplit red/blue, black housing
- IONDSplit red/white, black housing
- IONMSplit blue/amber, black housing
- IONW*Red, blue, amber or white, white housing
- IONWJSplit red/blue, white housing
- IONWDSplit red/white, white housing
- IONWMSplit blue/amber, white housing

OPTIONS

- IONK1BBlack bail bracket mount
- IONK1WWhite bail bracket mount



SINGLE COLOR 25 FLASH PATTERNS SPECIFICS

	PATTERN	SYNC	PHASES
1/2	SIGNAL ALERT 75	YES	1&2
3/4	COMET 75	YES	1&2
5/6	DOUBLE 75	YES	1&2
7/8	SINGLE 75	YES	1&2
9/10	COM-ALERT 75	YES	1&2
11/12	LONG BURST 75	YES	1&2
13/14	PING-PONG 75	YES	1&2
15	SINGLE 60	NO	1
16	SINGLE 90	NO	1
17	SINGLE 120	NO	1
18	SINGLE 300	NO	1
19	DOUBLE 150	NO	1
20	COM-ALERT 150	NO	1
21	ACTION FLASH 50	NO	1
22	ACTION FLASH 150	NO	1
23	MODU-FLASH	NO	1
24	ACTION SCAN	NO	1
25	STEADY	NO	1

NOTE: NON SYNC PATTERNS DO NOT GENERATE OR RESPOND TO A SYNC PULSE.

SPLIT COLOR 69 FLASH PATTERNS SPECIFICS

	PATTERN	SYNC	# SEQ	CAL
1/4	SIGNAL ALERT 75	YES	4	N
5/8	COMET 75	YES	4	N
9/12	DOUBLE 75	YES	4	Y
13/16	SINGLE 75	YES	4	Y
17/20	COM-ALERT 75	YES	4	N
21/24	LONG BURST 75	YES	4	N
25/28	PING-PONG 75	YES	4	Y
29/30	SSNF 75	YES	2	N
31A/32S	SINGLE 60	NO	2	Y
33A/34S	SINGLE 90	NO	2	Y
35A/36S	SINGLE 120	NO	2	Y
37A/38S	SINGLE 300	NO	2	N
39A/40S	DOUBLE 150	NO	2	N
41A/42S	COM-ALERT 150	NO	2	N
43A/44S	ACTION FLASH 50	NO	2	N
45A/46S	ACTION FLASH 150	NO	2	N
47A/48S	MODU-FLASH	NO	2	N
49A/50S	DOUBLE 120	NO	2	Y
51A/52S	PING-PONG 120	NO	2	Y
53A/54S	TRIPLE 75	NO	2	Y
55A/56S	TRIPLE 120	NO	2	Y
57A/58S	SIG-ALERT CAL	NO	2	Y
59A/60S	ACTION SF 60/120	NO	2	Y
61A/62S	ACTION SF120/TF75	NO	2	Y
63A&S	CAL SCAN	NO	1	Y
64A&S	ACTION SCAN	NO	1	N
65	STEADY FLASH 60	NO	1	Y
66	STEADY FLASH 75	NO	1	Y
67	STEADY FLASH 90	NO	1	Y
68	STEADY FLASH 120	NO	1	Y
69	STEADY & STEADY	NO	1	Y

NOTE: PATTERN NUMBERS FOLLOWED BY AN "A" ARE ALTERNATING, "S" IS SIMULTANEOUS

CAL = FLASH PATTERN IS CERTIFIED CALIFORNIA TITLE 13 COMPLIANT.
STEADY = STEADY FOR ONE SECOND THEN SLOW RAMP TO 40.

Whelen Engineering reserves the right to upgrade and improve products without notice.
© 2011 Whelen Engineering Company, Inc. Printed in U.S.A.
NASCAR® is a registered trademark of the National Association for Stock Car Auto Racing, Inc.
Code No. 12431C - 022311

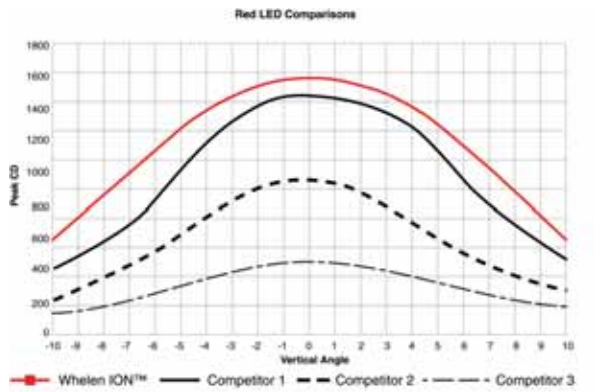

Vertical angle comparison of the ION against the three leading competitors.

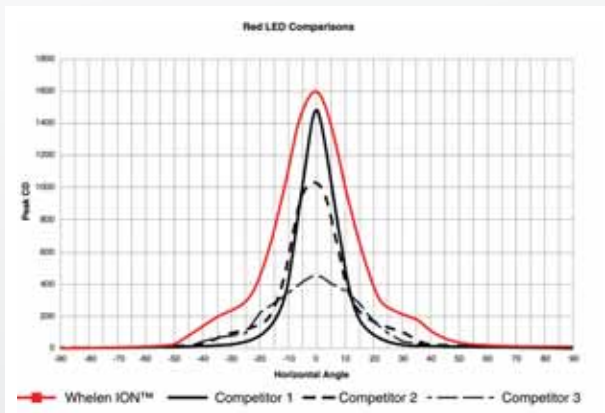

Horizontal angle comparison of the ION against the three leading competitors.

DIMENSIONS

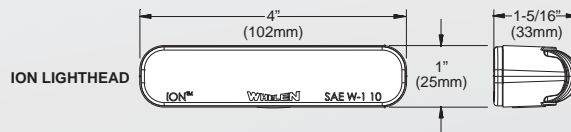

BAIL BRACKET MOUNT

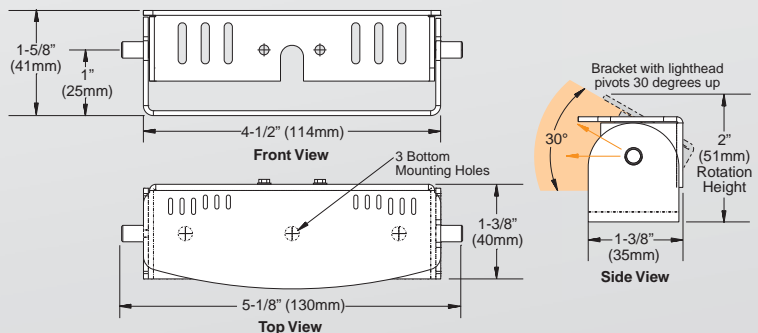

WHELEN®

ENGINEERING COMPANY, INC.

51 Winthrop Road
Chester, Connecticut 06412-0684
(860) 526-9504 • Fax: (860) 526-4078
www.whelen.com