

REV.	DESCRIPTION	DATE	APPROVED

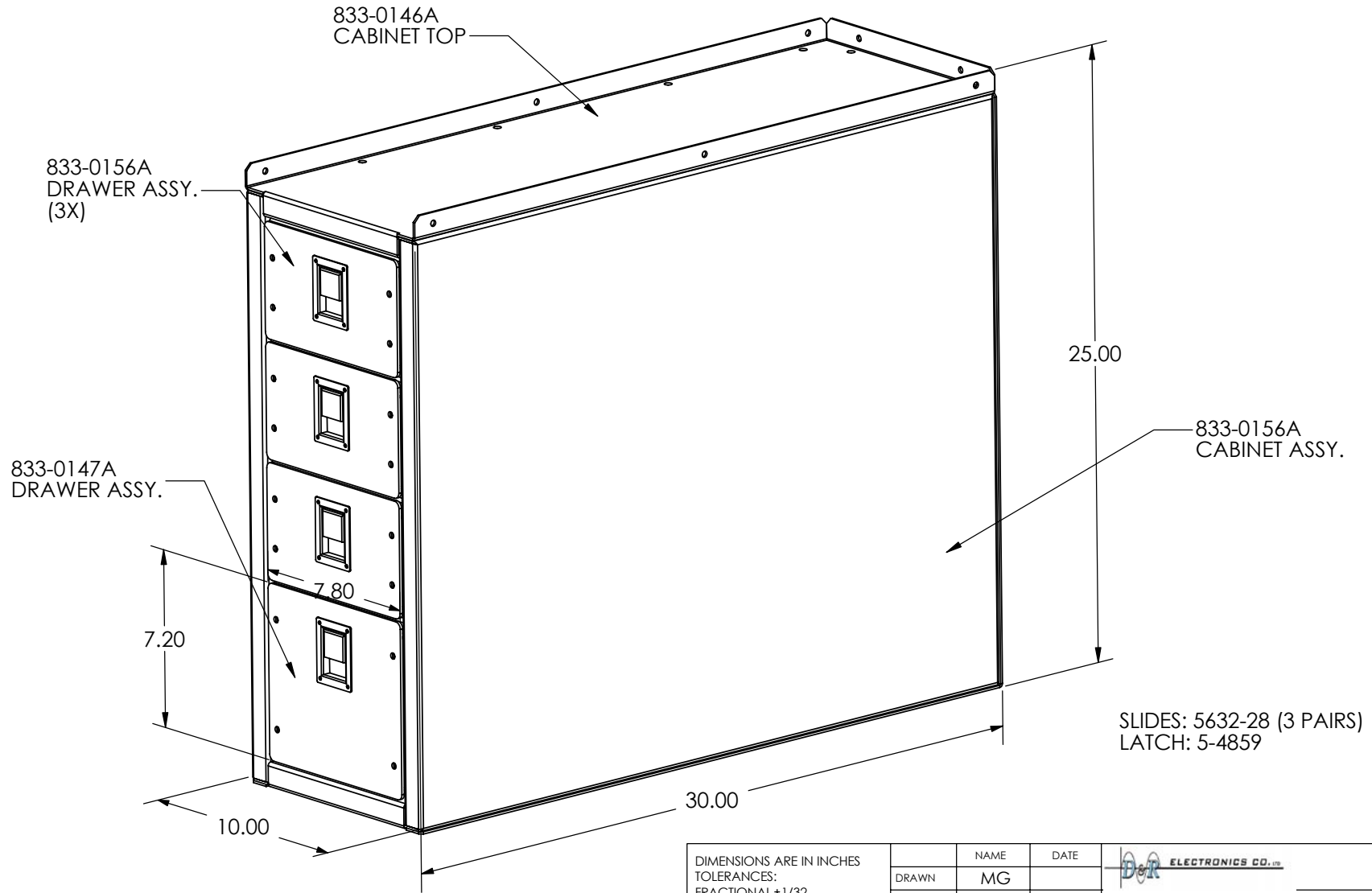

DIMENSIONS ARE IN INCHES TOLERANCES: FRACTIONAL ± 1/32 ANGULAR: ± 10° TWO PLACE DECIMAL ± .010 THREE PLACE DECIMAL ± .005		NAME MG	DATE	
MATERIAL	Q.A.			
FINISH	COMMENTS:			<b>Truckstor TS-02-4D</b> Path: M:\ENG_DATA\storage_drawers\933\TS-02-4D\ File: 933-0005A Date: Tuesday, May 10, 2005 9:13:11 AM
		SIZE <b>A</b>	DWG. NO. 933-0005A	REV. 0
USED ON:			SHEET 1 OF 1	