

PCC_W Series

4, 6 and 10 LIGHT SWITCHING POWER CONTROL CENTERS

Four, six and ten switch control centers provide complete control in a fully assembled, low cost package.



PCC6W



PCC10W



PCC4W

FEATURES

- Compact Design.
- Rocker style single pole/single throw switches, rated at 25 amps peak, with 'active' LED indicators that light up to indicate function in use.
- Individual spade-type fuses conveniently located on rear mounted fuse strip.
- Ignition controlled backlighted legend windows for easy visibility in any light.
- Backlight circuit can be connected to vehicle dimmer switch to control backlight intensity.
- 72 commonly used press-on switch function label legend tabs standard.
- Black epoxy-finished, steel housing.
- Common ground post for ease of installing.
- 12 VDC.

PCC6W and PCC10W only

- PCC6W has six 25 amp switches.
- PCC10W has ten 25 amp switches.
- PCC6W/PCC10W have "piano style" backs with rear mounted "captive" terminal block for easy installations.
- Aftermarket console mounting recommended but includes an adjustable 2 position universal bail bracket strap mounting kit for over or under dash mounting.
- Adjustable bracket overall heights: 3-3/8" (86mm) H (lower bracket position), 3-3/4" (96mm) H (higher bracket position).

PCC4W only

- Four 25 amp switches.
- Flying leads connection
- Includes an adjustable 2 position universal bail bracket strap mounting kit for over or under dash mounting.
- Adjustable bail bracket overall heights: 2-3/4" (70mm) H (lower bracket position), 3-1/4" (83mm) H (higher bracket position).

WHELEN®

PCC_W Series Power Control Centers

MODEL

PCC4WFour 25 amp switches.

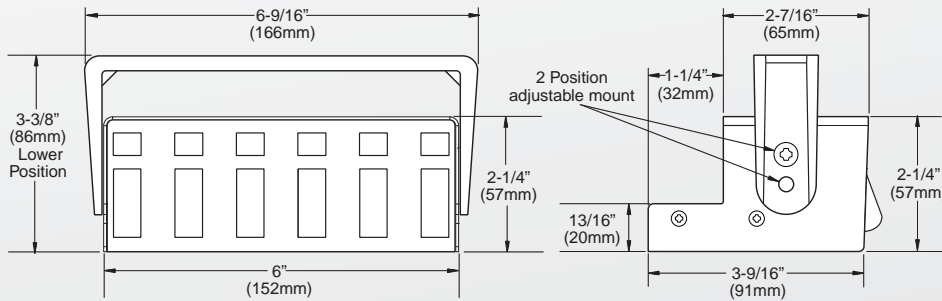
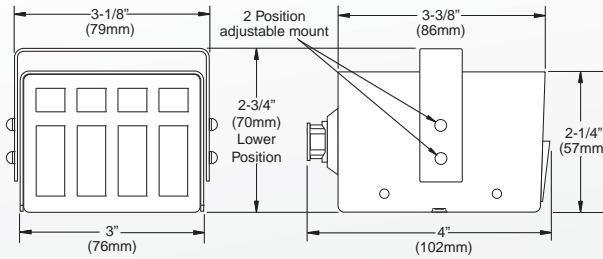

MODEL

PCC6WSix 25 amp switches.



MODEL

PCC10WTen 25 amp switches.



Rear view showing the "captive" terminal blocks for easy installations and individual spade-type fuse strip

WHELEN[®]

ENGINEERING COMPANY, INC.

51 Winthrop Road
 Chester, Connecticut 06412-0684
 (860) 526-9504 • Fax: (860) 526-4078
 www.whelen.com

Whelen Engineering reserves the right to upgrade and improve products without notice.
 © 2011 Whelen Engineering Company, Inc. Printed in U.S.A.
 Code No. 10831E - 060211

American Employees, American Manufacturing, American Pride!